



Midsized Extractor

OPERATORS MANUAL AND PARTS LIST

Model PFX1080 SERIES



WARNING: OPERATOR MUST READ AND UNDERSTAND THIS MANUAL COMPLETELY BEFORE OPERATING THIS EQUIPMENT.

IMPORTANT SAFETY PRECAUTIONS

WARNING! To reduce the risk of fire, electric shock, or injury

WARNING
To avoid fire, DO NOT use with a flammable or combustible liquid to clean floor.



WARNING
To avoid electric shock, DO NOT expose to rain. Store Indoors.

When using this upright extractor, basic precautions should always be followed, including the following:

- 1) **DO NOT** leave unit when plugged in. Unplug from outlet when not in use and before servicing.
- 2) **DO NOT** allow unit to be used as a toy. Close attention is necessary when used around or near children.
- 3) Use only as described in this manual. Use only manufacturer's recommended attachments.
- 4) **DO NOT** use with damaged cord or plug. If unit is not working properly because it has been dropped, dropped into water, left outdoors, or damaged in any way, contact an authorized service center.
- 5) **DO NOT** handle plug or appliance with wet hands.
- 6) **DO NOT** put any objects into openings. **DO NOT** use with any opening blocked: keep free of dust, lint, hair, or anything that may reduce air flow.
- 7) Keep hair, loose clothing, fingers, and all parts of body away from openings and moving parts.
- 8) **DO NOT** pick up anything that is smoking or burning such as cigarettes, matches, or hot ashes.
- 9) **DO NOT** use to pick up hazardous chemicals.
- 10) Turn off all controls before unplugging.
- 11) Turn unit off immediately if foam or liquid comes from machine exhaust. Empty & clean out recovery (dirty) tank and use defoamer to correct the problem.
- 12) **DO NOT** use to pick up flammable or combustible liquids such as gasoline or use in areas where they may be present.
- 13) **DO NOT** use where oxygen or anesthetics are used.
- 14) Replace damaged or worn parts immediately with genuine original equipment parts to maintain safety.
- 15) This unit must be connected to a properly grounded outlet only. See grounding instruction on page 3.

GROUNDING INSTRUCTIONS

DANGER: Improper use of the grounding plug can result in a risk of electric shock.

GROUNDING INSTRUCTIONS

This extractor must be properly grounded. If it should malfunction or breakdown, grounding provides a path of least resistance for electrical current to reduce the risk of electric shock. This machine is equipped with 1 or 2 pigtail cords having an equipment-grounding conductor and grounding plug. The pigtails must be inserted into an appropriate 12 gauge 3 prong extension cord. This unit is for use on a nominal 120 volt circuit and has a grounded plug that looks like the plug illustrated in (Fig. A).

GROUNDING METHODS

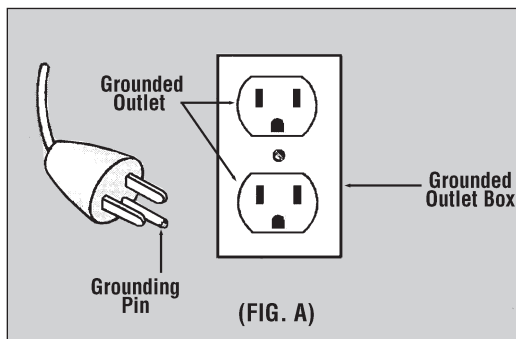

This unit is for use on a nominal 120 volt circuit and has a grounded plug that looks like the plug illustrated in (Fig. A).

WARNING!

Improper connection of the equipment-grounding conductor can result in a risk of electric shock. Check with a qualified electrician or service person if you are in doubt as to whether the outlet is properly grounded. **DO NOT** modify the plug provided with the appliance. If it will not fit the outlet, have a proper outlet installed by a qualified electrician.

General instructions for PFX1080 series Extractors

Congratulations on your purchase of a Powr-Flite extractor. You are now equipped to handle any and all commercial carpet cleaning jobs.

Shipping and Damage

This equipment is thoroughly inspected, tested, and packaged to provide equipment in good operating condition. It is beyond our control after the equipment is turned over to a freight carrier. The freight carrier received and signed for the equipment in good condition. Consequently, it is most important to protect your interest by carefully complying with the following instructions:

Please inspect your cartons for any damage (including concealed damage) that might have occurred during shipment. Any damage is the responsibility of the freight carrier and should be reported to the freight carrier immediately. It is your responsibility to issue a claim and to receive compensation from the freight carrier for any damage done in transit. Damage of this sort is not warranted.

Follow these easy step-by-step instructions to ensure proper operating performance.

1. Fill up the fresh water solution tank with tap water that is 120-135 degrees and approved carpet cleaning chemical, if you are not pre-spraying your chemical on the carpet.
2. Attach two 12 gauge extension cords (NOT INCLUDED) (one cord for non-heated models) to each of the pigtail cords located on the lower backside of the unit. The red pigtail powers the heater while the black pigtail powers the vacuum motors and pump.
3. Plug each extension cord into a separate and grounded 20 amp wall socket circuits. When this is accomplished the green indicator light will be lit (on heated models).
4. Attach the hose system to the unit and to your carpet wand.
5. Turn on the heater and the pump to the "on" position, (only pump on non-heated models). When the heater is on, the orange indicator light on the switch panel will be lit.
6. With the solution line attached to the wand and the achine, prime the pump by squeezing the trigger on the wand releasing the water (hold wand tip over solution tank to put water back into solution tank). This will pump water into the heater and get any air out of the solution line. Let the heater heat up this will take 3 to 5 minutes. *Prime pump on 400 p.s.i. models with prime hose (included).
7. Turn vacuum switches to the "on" position one at at time to begin cleaning.
8. Anyone designated to operate this equipment must read and thoroughly understand all instructions and precautions prior to use.
9. Never use equipment out of doors or in the rain.
10. Never use flammable or explosive materials in or around this equipment!
11. When vacuum tank is full, empty by using dumping valve on the front of the machine. If a pail is used to empty the vacuum waste tank, do not use the same pail to fill the solution tank as this can result in putting dirt and grit into the solution line that can plug filters, orifices, and generally degrade the solution line system (do not reuse solution).
12. To empty solution tank, detach the wand from the end of the vacuum hose and insert the vacuum hose into the solution tank. Turn the vacuum switches to "on" position and transfer solution to vacuum tank and dispose of as outlined in #11. Clean vacuum stack filter at this time.

Maintenance

To receive reliable service from this equipment, regular daily maintenance is a required.

1. Keep the equipment clean, both inside and out.
2. Lubricate brass quick disconnects and drain valves with a quality lubricant such as WD-40®.
3. Flush solution systems after use with clear, clean water. (A white vinegar solution may also be used). This will counter-act hard water and alkaline deposits and aid in keeping orifices clean.
4. Do not allow fluid, either in solution or waste tank, to sit overnight. The unit should be emptied and cleaned daily.
5. Clean the strainer in the solution tank, the filters on the vacuum stack in vacuum tank, and all lint filters in the inlet or vacuum tanks daily.
6. Do not use the same receptacle (pail) to fill solution tank that is used to remove waste from vacuum tank.
7. When the unit is not in use, leave the vacuum tank lid open.
8. At the end of each day, run the vacuum for 3 minutes with lid open and filter off.

Safety Precautions

These precautions are designed with the safety of the operator, the equipment, and others in mind and must be followed at all times to avoid serious personal harm and/or death, and damage to the unit.

1. Always use a grounded electrical outlet.
2. Always disconnect electric cable from electrical outlet before attempting to make any adjustments or repairs.

3. Never use this equipment as a toy.
4. Never use equipment near or around flammable or explosive materials, fuels, or solvents.
5. Never put flammable materials, fuels, or solvents into equipment.
6. Never lift the machine by dumping valve.
7. Do not allow the unit to freeze!
8. The equipment was not designed to be used outdoors or in the rain.
9. Do not operate in standing water.
10. Wear safety equipment and clothing to protect from extremely hot water.
11. Do not operate equipment under any unsafe condition.
12. Do not operate if pigtailed, hoses, etc. are cracked, frayed, leaking, or otherwise in need of repair.



Storage of Equipment

1. Store extractor indoors in dry area.
2. Recovery and solution tank should be empty and clean when the extractor is not in use.
3. Leave the recovery lid and dump valve open to air out the recovery tank.
4. Do not store in freezing temperature.
5. A small amount of windshield washer fluid may be left in the pump and internal solution line for protection against freezing.

Warnings

1. Do not break off or pull the grounding prong on the plug.
2. Do not attempt repair on a warranted machine unless instructions to perform it by an authorized shop are obtained from the factory.
3. Do not use citrus-based (D-Limonene) cleaners in this machine.
4. Do not use cleaning chemicals in this machine except those recommended for steam-type extraction equipment. The use of any chemicals with abrasive additives voids the warranty.

5. Do not use any replacement parts except those specified on the parts list. Performance of the machine could be affected if substitutions are made.
6. Do not use water in excess of 140° F (62° C) through the pump system. It could damage the seals and polypropylene casing of the diaphragm pump.
7. Follow maintenance schedule strictly.
8. **Failure to comply with the above warnings instructions will void the warranty.**



ONE LAST REMINDER

Read All Instructions, Warning and Cautions Before Using. These guidelines are presented for your protection and convenience. Please read them carefully, since failure to heed these precautions could result in discomfort or injury. When using an electrical appliance, basic safety precautions should always be followed.

WARNING

TO AVOID FIRE, DO NOT USE WITH A FLAMMABLE OR COMBUSTIBLE LIQUID TO CLEAN FLOOR.